

# Design and Analysis of a Distributed and Fair Access (DFA) MAC Protocol for Multihop Wireless Networks

Lei Pan, Xiaojun Cao, and Hongyi Wu

**Abstract**—The Distributed and Fair Access (DFA) protocol is proposed for multihop wireless networks. The proposed protocol eliminates several problems existed in the original binary countdown (BCD) algorithm, such as lack of fairness, data collision and the inefficiency of channel usage, by introducing hidden-station elimination and second chance channel contention that are suitable for multihop networks. Further in this paper, numerical analysis of modeling the behavior of DFA in multihop networks are presented. With low computational complexity, the proposed model estimates the transmission probability and the channel throughput. In our analysis, the data transmission influenced by the remote stations is carefully monitored and analyzed. Our extensive simulation results have verified the proposed model and demonstrated the superior performance of DFA comparing with other existing MAC protocols including the IEEE 802.11 and SYN-MAC [1]. Equipped with many attractive features such as high efficiency, fairness, simplicity and robustness, DFA can be served as a promising alternative MAC protocol for the distributed wireless networks.

**Index Terms**—Medium Access Control, multihop analysis, binary countdown algorithm, channel throughput, distributed wireless network.

## I. INTRODUCTION

WITH its unmatched flexibility to support the communication of mobile users, the self-configurable multihop wireless network has become increasingly popular. This also brings design challenges to the Medium Access Control (MAC) sub-layer, such as: (a) how to solve the hidden/exposed station problem and improve the network throughput; (b) how to model the influence from remote stations to a particular data transmission; and (c) how to manage the packet contention fairly and efficiently when stations have asymmetric information about the channel conditions, etc. As a result, the MAC protocols proposed for single-hop networks do not naturally fit in multihop scenarios. For example, in wireless mesh networks (WMNs), WRs transport data between mobile hosts (MHs) and a limited number of Internet gateway routers,

and hence, form the backbone of WMN. Given the popularity of IEEE 802.11 devices, the MH-to-WR communications are based on the existing IEEE 802.11 Distributed Coordination Function (DCF) MAC protocol. However, a WR must relay a large amount of traffic, for not only nearby MHs but also remote WRs multiple hops away. Therefore, the traffic loads at WRs are usually heavy. It has been revealed in several literatures that DCF does not perform well under heavy traffic load, especially in multihop networks, making it inappropriate for WR-to-WR communication in large scale WMNs. [2], [3], [4].

The versatility of multihop networks brings significant challenges to the analysis of MAC protocols, since the complexity of modeling stationary behavior grows exponentially with the network size. Furthermore, because the interference range of a wireless node is usually larger than its communication range, the performance analysis of multihop wireless networks becomes more difficult. This in fact continues to be an area that deserves considerable research. In this paper, we propose a Distributed and Fair Access (DFA) MAC protocol for multihop wireless networks. Similar to the SYN-MAC protocol [1], DFA adopts binary count down (BCD) algorithm tailored for wireless stations and ensures data transmission to be collision-free. However, with its primary focus on single hop, the SYN-MAC protocol does not offer optimal channel efficiency when the transmitter and the receiver are located in different collision domains. Our proposed DFA protocol is able to adjust data transmission and optimize network throughput in multihop networks, by giving stations the second (or more) chances to contend the channel if they failed at the first time. The beauty of DFA is its ability to offer stations more transmission opportunities without incurring extra overhead to the existing data transmission.

We further provide approaches to analyze stationary behaviors in multihop networks that may be generalized for other MAC protocols as well. By knowing the neighbors of the transmitter and the receiver, our approach can predict the probability of successful data transmissions. The wireless interference model is considered in the analysis. The proposed approach may also be used to approximate the channel throughput for random networks given the average nodal density (i.e., the average number of nodes in single collision domain). It is shown that the performance of DFA is better than other existing MAC protocols including SYN-MAC and the IEEE 802.11 DCF.

This paper is organized as follows: Section II discusses the

Manuscript received November 12, 2007; revised January 31, 2008, April 13, 2008, and June 2, 2008; accepted June 4, 2008. The associate editor coordinating the review of this paper and approving it for publication was E. Hossain.

This work is supported in part by National Science Foundation CAREER Award under Award Number CNS-0347686 and by U.S. Department of Energy (DoE) under Award Number DE-FG02-04ER46136.

L. Pan and H. Wu are with the Center for Advanced Computer Studies, University of Louisiana at Lafayette, Lafayette, LA 70504 (e-mail: {lxp1250, wu}@cacs.louisiana.edu).

X. Cao is with the Department of Computer Science, Georgia State University, Atlanta, Georgia 30303 (e-mail: xiaojuncao@ieee.org).

Digital Object Identifier 10.1109/TWC.2009.071263

related work to MAC protocol design and modeling, as well as the synchronization issues in the wireless networks. Section III describes our proposed DFA protocol. Section IV presents the analytical model for DFA in multihop networks. Section V validates our proposed model and compares the performance of several MAC protocols. Finally, Section VI concludes the paper.

## II. RELATED WORK

Wireless MAC protocols can be broadly categorized as contention-based and contention-free, depending on the channel access mechanisms. The centralized contention-free MAC protocols can be either TDMA/CDMA/FDMA based protocols that adopt fixed channel access scheduling or polling algorithm [5], [6]. These algorithms require the coordination of a central controller, such as a base station or an access point. Although the token-ring based wireless MAC protocol provides a distributed way to offer contention-free channel access, it assumes full connectivity of the network [7]. Therefore, contention-free MAC protocols are not suitable for distributed multihop wireless networks. Instead, the contention-based MAC protocols are commonly adopted, providing great flexibility to allow stations to access the channel without predetermined schedules. There are many random access algorithms proposed, using various collision avoidance and resolution schemes such as virtual carrier sensing, multi-channel, directional antennas, random back off and synchronization. These protocols have been well studied, and thus the details are skipped here. In general, a contention-based protocol usually is superior when the network load is light. When the network load is heavy, many stations attempt to access the channel simultaneously, causing the system performance downgraded.

Many analyses have been proposed to evaluate MAC protocols. Among them, most are based on the assumption of fully-connected single hop networks [8], [9], [10]. Recently, there have been considerable interests to study the channel throughput of multihop wireless networks. In [11], [12], mathematical models are proposed to obtain the theoretical bounds of the channel capacities. However, protocol-specific analytical models are critical for performance evaluation. By far, most literatures with the analysis of multihop network are focused on the CSMA/CA-based 802.11 DCF. For example, data transmissions are decomposed into embedded two-flow pairs (i.e., only consider two ongoing transmissions at a time) in [3] to analyze the the performance of DCF. But it remains challenging to investigate station behaviors with multiple interference flows in the network. A scheduling scheme with spatial reuse TDMA-like MAC protocols is proposed in [4] to solve channel collision problems by using greedy algorithm. It requires the traffic demands are stable and known a priori, and thus it is difficult to implement in a distributed manner. An analytical model is developed to study the IEEE 802.11 DCF by considering different collision domains for data transmission in [13]. However, it does not consider the influence from remote stations. Moreover, the above mentioned protocols do not consider the impact of wireless interference to the network performance, which is an

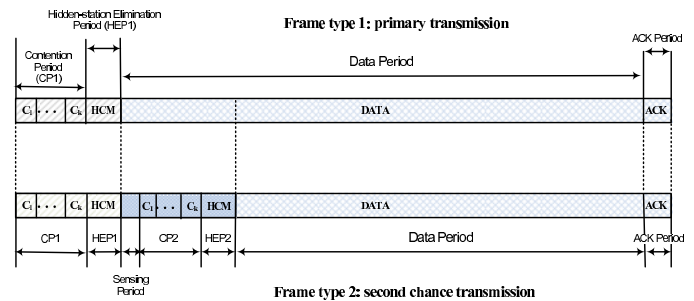

Fig. 1. The proposed DFA protocol.

important factor when we study wireless MAC protocols [14], [15].

Furthermore, time synchronization is critical in all distributed computer systems including wireless networks. For example, a sensor network uses synchronization for data integration, sensor reading fusion, packet scheduling and power saving. In IEEE 802.11 networks with Point Coordination Function (PCF) enabled, base stations need to have precise time synchronization to transmit and receive data. The most commonly adopted synchronization approaches include the employment of the Global Positioning System (GPS), the Network Time Protocol (NTP), the Pulse-per-second (PPS) signal interfacing or integrating with the cellular systems, and several other approaches proposed recently for mobile ad hoc networks and sensor networks. An adaptive clock synchronization using Reference Broadcast Synchronization (RBS) is proposed in [16] to provide synchronization of high accuracy. In [17], an approach derived from NTP is designed to offer accurate synchronization to radio base stations in simulcast networks.

## III. PROTOCOL DESCRIPTION

The Distributed and Fair Access (DFA) protocol is described in this section. In DFA, the network time is divided into synchronous frames of equal length. A frame can be one of the two types shown in Fig. 1. The Type 1 frame is composed of four intervals: the Contention Period (CP1), the Hidden-station Elimination Period (HEP1), the Data Period (DP) and the ACK Period (ACK). The Type 2 frame is similar, except there is another short interval (including a Sensing Period (SP), CP2 and HEP2) at the end of HEP1. Therefore, there are seven intervals included in the Type 2 frame: CP1, HEP1, SP, CP2, HEP2, DP and ACK.

### A. The Primary Data Transmission in DFA

A rectified binary countdown approach is adopted in the CP to resolve channel contention. The CP is divided into  $K$  time slots denoted as  $C_1C_2\dots C_K$ . If Station  $U$  has a packet to send, it generates a  $K$ -bit random contention number denoted as  $b_1\dots b_K$ . In a time slot  $i$ , if  $b_i = 1$ , Station  $U$  sends a Contention Signal (CS) that contains the receiver's MAC address; otherwise, it listens to the channel. If Station  $U$  has no packet to transmit, it also listens to the channel. Depending on the channel condition it hears, one of the following actions is taken:

- 1) If Station  $U$  receives a valid CS with other's MAC address (i.e., it correctly receives the CS; the MAC

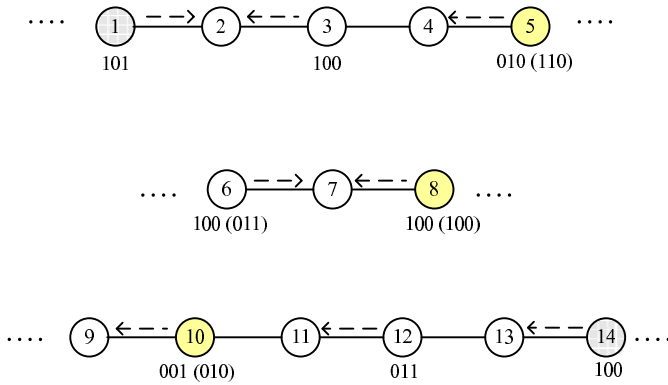

Fig. 2. An example of DFA.

address in the CS does not match with its own MAC address), it gives up for this frame and goes to sleep mode to save energy consumption;

- 2) If Station  $U$  receives a valid CS with its own MAC, it marks itself as the receiver for this frame and generates a  $K$ -bit string as *contention mask*, with the  $i$ -th bit being 1 and all other bits being 0. For example, if  $K = 4$  and the station receives a CS containing its MAC address in the third slot, the *contention mask* will be 0010. After that, it goes to the sleep mode until the end of the contention period;
- 3) If there is collision, Station  $U$  gives up any channel competition. However, it will listen in the next slot to find out who the receiver is;
- 4) If Station  $U$  does not hear anything (i.e., the channel is idle), it repeats the above rules in the next slot.

To solve the hidden station problem that causes data collision in multihop networks, the HEP is introduced to ensure the data transmission to be collision free. In the HEP, the marked receiver sends a Hidden station Clear Message (HCM), which contains the *contention mask* it generated earlier. Meanwhile, the sender that finishes transmitting all the Contention Signals (CSs) without sensing channel occupied in the CP (referred as “local winner”) will listen to the channel. Upon receipt of a valid HCM, the sender computes the bitwise AND of the *contention mask* carried in the HCM with its own contention number. It is allowed to transmit in the data period only if the result is nonzero. Finally, the data period and ACK period are designed for data and ACK transmissions. With this scheme, the data transmission is ensured to be collision free.

Fig. 2 provides examples to illustrate the DFA protocol. A solid line implies the two connected stations are within the same collision domain (i.e., within the communication range of each other) and a dotted arrow indicates the intended data transmission. The 3-bit random contention numbers generated by the senders are listed under the Station ID. (The numbers enclosed by “( )” are for the second chance transmission to be described in Section III-B). There are three different sets in Fig. 2. Set 1 includes Stations 1-5, Set 2 includes Stations 6-7 and Set 3 includes Stations 9-14. There is no interference among any stations in different sets. First of all, we explain the activities in Set 1 (Stations 1-5).

- In the first contention slot, both Station 1 and Station 3

send contention signals (CS) with the MAC address of Station 2. A collision occurred at Station 2 as a result. However, Station 4 correctly receives the CS from Station 3 (indicating Station 2 is the receiver). According to the rule, it marks itself unavailable and goes to sleep for the remaining of this frame.

- In the second slot, Station 5 sends a CS. However, Station 4 will ignore this CS since it is unavailable for the current frame.
- In the third slot, Station 1 sends CS again. This time, Station 2 correctly receives the CS and marks itself as the receiver with a *contention mask* of 001.

At the end of CP1, all senders move to HEP1 because none of them senses the channel occupied in CP1. However, only Station 2 will send an HCM that allows Station 1 to transmit data.

Meanwhile in Set 2, Stations 6 and 8 are competing for the channel using the same contention number as indicated in the figure. Their common receiver, Station 7, is not able to receive any valid CS due to the collision in CP1. In Set 3, Stations 13, 11 and 9 get a valid CS from their intended sender in the first, second and third contention slot, respectively, during CP1. All of them will send HCMs in HEP1, and thus cause collisions at Stations 10 and 12. In the data period, transmission from 14 to 13 is successful. As a result, Stations 1 and 14 will transmit in the data period free of collision.

Note that, the proposed DFA protocol has considered the effect of the interference range (greater than the communication range) and effectively eliminated the hidden station problems that will occur in RTS/CTS based protocols. In the DFA protocol, an undecoded message sent by a station outside the communication range but within the interference range is treated as collision. In the other words, a station is not allowed to proceed transmission if it receives a “vague” message. To send data, two conditions must be satisfied: first of all, a station cannot receive any message (undecoded or not) in the contention period; secondly, a station must receive a clear HCM that indicates it is the sender (i.e., the AND operation of the receiver’s contention mask and the sender’s random number is nonzero). Failure to meet either condition disqualifies a station from being a sender.

### B. The Second Chance Transmission

In multihop networks, the channel status acknowledged by different stations are not synchronous even with carrier sensing. For example, in Fig. 2, Station 4 has no knowledge that Station 3 already gives up after HEP1. The asymmetric information distribution leads to the inefficiency of channel usage, because it is clear that the data transmission from Station 5 to Station 4 could be permitted without causing any interference. Similarly, preventing data transmissions  $8 \rightarrow 7$  and  $10 \rightarrow 9$  are also unnecessary.

To reclaim the channel resources, DFA introduces a second chance to the stations that failed earlier. More specifically, when the winning station is transmitting data after HEP1, other non-receiving stations sense the channel for a short sensing period (SP) as shown in Fig. 1. If a station hears any ongoing transmission during HEP1 or SP, it will mark itself

as unavailable (and may sleep in the data period). A station concludes that the channel is clear if it does not hear any transmission in either HEP1 or SP, and marks itself available for the second chance. The second chance channel competition (during CP2 and HEP2) uses the same rules described in Sec. III-A, with new random contention number from the sender. In the DP, the sender delivers the data packet to the receiver by employing Type 1 or Type 2 frame, based on when it wins the channel. To improve the network performance, the data period is designed to be large enough to carry multiple packets in one transmission. It is assumed that a station will arrange the packet fragmentation/defragmentation according to the frame type before transmission.

With the second chance, there are more eligible stations allowed to transmit data concurrently, achieving optimal channel utilization. As depicted in Fig. 2, since Stations 4 and 5 do not sense ongoing transmission during HEP1 or SP, Station 5 can contend for the channel again in CP2 with another contention number as indicated in the “( )”, which will be correctly received by Station 4. Similarly, with the second chance, Stations 8 and 10 regain the permission to transmit data. At the end of HEP2, new data transmissions  $5 \rightarrow 4$ ,  $8 \rightarrow 7$  and  $10 \rightarrow 9$  are allowed simultaneously.

Note that, our proposed DFA is not limited to the second chance only. In fact, the same approaches can be adopted for the third, fourth... chance in data transmission to increase the successful ratio, as long as the length of data period can carry at least one data packet. To avoid repetitive explanation, only the second chance scenario is applied to the model and simulation.

To participate in the CP for channel contention, a sender needs to generate a  $K$ -bit random number, according to the rules of the DFA protocol. Therefore, the protocol guarantees fairness in data transmission, which is a desirable feature for distributed networks. On the other hand, by appending QoS (Quality-of-Service) bits to the random number, DFA can efficiently achieve QoS support while still maintaining the fairness under each priority class. For the scope of this paper, a single priority class is adopted.

### C. Synchronization in the DFA Protocol

As explained in Sec. I, the DFA protocol is proposed for the wireless routers (WRs) in WMNs, thus a simple and effective scheme can be employed for synchronization. More specifically, the gateway node serves as the primary time server and broadcasts a synchronization beacon, which contains the time stamp (i.e., its current clock time denoted by  $t_1$ ) and its transmission power, to the neighboring stations within its communication range. Upon receipt of the beacon, a station adjusts its own clock accordingly. Let  $t_d$  denote the propagation delay, and  $t_p$  the processing time (i.e., the time needed for processing at the receiver's network interface). We have

$$t_2 = t_1 + t_d + t_p, \quad (1)$$

which is adopted by the receiving station to set its clock. Once a station is synchronized, it becomes a secondary time server and may repeat the above process by broadcasting beacon to synchronize its neighbors. The above discussion is based on

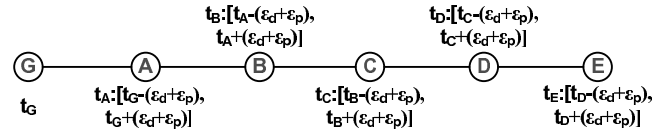

Fig. 3. Synchronization errors in the DFA protocol.

single gateway in the network. If there are multiple gateways, one of them can be designated as primary time server; or several well synchronized gateways may become primary time servers simultaneously (via approaches mentioned in Sec. II).

Clearly, this simple approach may lead to synchronization errors, which stem from  $t_d$  and  $t_p$  that are unknown parameters and can only be estimated in practice. For example, the transmission and reception power are used to estimate the distance and in turn the signal propagation delay,  $t_d$ . On the other hand,  $t_p$  may be estimated according to the processor speed of the network interface card. The better the estimation, the higher the synchronization accuracy. Denote the maximum estimation errors in  $t_d$  and  $t_p$  as  $\epsilon_d$  and  $\epsilon_p$ , respectively. There is an error of up to  $\epsilon_d + \epsilon_p$  between the clocks of the gateway (see Station  $G$  in Fig. 3) and its neighbors (e.g., Station  $A$  in Fig. 3). Such errors may accumulate during the synchronization process. As a result, a station far away from the gateway (e.g., Station  $E$  in Fig. 3) may have a clock error up to multiple times of  $\epsilon_d + \epsilon_p$ . However, the time difference between any two adjacent stations is bounded by  $\epsilon_d + \epsilon_p$ .

The synchronization errors can be addressed by using guard band. Consider two stations, e.g.,  $X$  and  $Y$ , which are in a collision domain and contend for channel access. Due to the errors in synchronization, their contention signals (CSs) in consecutive contention slots may overlap as depicted in Fig. 4(a) (e.g., Station  $Y$  is still transmitting CS1 when Station  $X$  starts to transmit CS2), resulting in collisions and possible failure of DFA. This problem, however, can be solved by using guard band. As illustrated in Fig. 4(b), we may increase the contention slot by a guard band (i.e., an interval of  $2(\epsilon_d + \epsilon_p)$ ), so that the CSs in different contention slots never overlap. Note that, a shift between two CSs in the same contention slot does not affect the DFA protocol.

Clearly, the use of guard band increases overhead. Thus the guard band should be minimized to achieve the highest channel efficiency. We have carried out simulations to estimate  $\epsilon_d$  and  $\epsilon_p$  for determining the appropriate guard band. For example, we have simulated an area of 10 km by 10 km with 500 stations randomly distributed. The communication range is set to 500 meters. It is assumed the propagation delay model has up to 20% error. The simulation results reveal that over 98% propagation errors ( $\epsilon_d$ ) are within  $0.3\mu s$  and the maximum error is  $0.33\mu s$ . In addition,  $\epsilon_p$  is far below  $1\mu s$  for a 2GHz processor. Therefore, a guard band of  $2\mu s$  is offered for the synchronization in the proposed DFA protocol. As we have discussed earlier, a station far away from the gateway may have a large clock error. Fortunately, such error does not affect DFA, which can work properly as long as the time difference between any two adjacent stations is bounded by the guard band, as explained above.

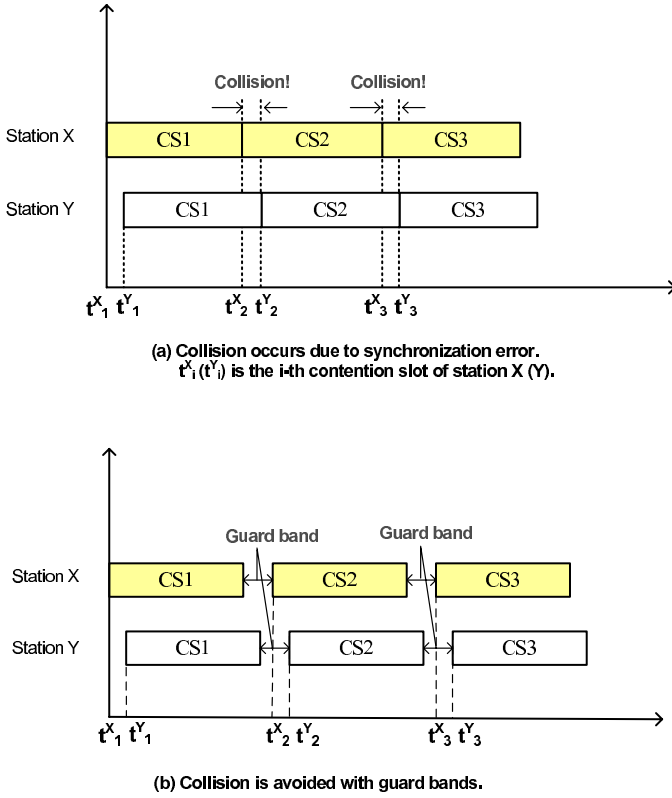

Fig. 4. Guard band used in the DFA protocol.

#### IV. ANALYTIC MODEL FOR THE DFA PROTOCOL

An analytical model to approximate the channel throughput of DFA in multihop networks, including the primary and the secondary data transmissions, is provided in this section. We will further discuss the influence from remote stations to the current transmission. Our analytical model also considers the effect of the interference range.

##### A. The Primary Data Transmission

To simplify the explanation, it is assumed that each transmitter randomly selects its neighbor (in the communication range) to send data. The actual chance of a station being selected as the receiver depends on the routing algorithm provided by the upper layer. Fig. 5 shows an example of data transmission in a multihop network. Denote  $n_t$  (or  $n_r$ ) as the number of stations within the interference range of the transmitter  $T$  (or the receiver  $R$ ), and  $n_o$  as the number of the common neighbors located in the overlapping area of the transmitter and the receiver (the shaded area in Fig 5). Denote  $n_c$  as the number of stations within the communication range of the transmitter.

In multihop networks, the transmitter's collision domain is not totally overlapped with the receiver's, therefore, the information (channel condition) acquired by the transmitter and the receiver during the carrier sensing is asynchronous, which greatly increase the complexity of modeling data throughput. To prevent data collision and ensure the successful transmission from  $T$  to  $R$ , according to the rule of DFA, all of the following probabilities must be met:

- $\alpha_1$ : the probability that  $R$  receives at least one contention signal (CS) from  $T$  correctly;

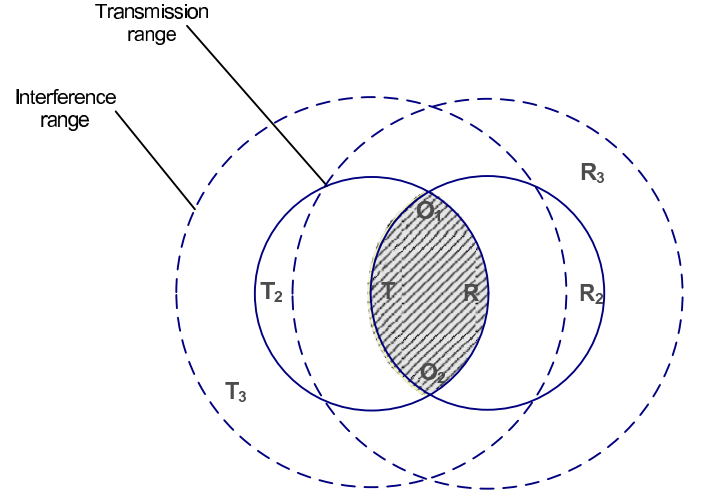

Fig. 5. Transmission in multihop networks.

- $\alpha_2$ : the probability that  $T$  sends out all of its CSs without hearing channel busy; and
- $\alpha_3$ : the probability that  $T$  receives  $R$ 's HCM correctly.

Let  $k_t$  be the contention number generated by  $T$ .  $\alpha_1$  is the probability that Station  $R$  can correctly receive at least one CS from  $T$  and mark itself as the receiver. To satisfy  $\alpha_1$ ,  $T$  must generate the unique largest contention number among all stations in the collision domain of  $R$ , including Station  $R$  and all of its neighbors except the transmitter  $T$ , totally  $n_r$  stations.

With  $K$  contention slots, a ready sender will generate a random number from 0 to  $2^K - 1$  with the uniform distribution. The probability to generate a contention number is thus  $\frac{1}{2^K}$ . And the probability that a station generates a contention number less than  $k_t$  is, therefore,  $\delta = \frac{k_t}{2^K}$ .

Depending on the packet arrival pattern and rate, the probability of a station with data to send at the beginning of a DFA frame can be calculated. For the simplicity, it is assumed that a station has data to transmit in every frame. Hence  $\alpha_1$  can be derived as

$$\alpha_1 = f_1(k_t) = \left( \frac{k_t}{2^K} \right)^{n_r}. \quad (2)$$

In Fig. 5,  $\alpha_1$  applies for Stations  $R, O_1, O_2, R_2$  and  $R_3$ .

$\alpha_2$  is the probability that  $T$  sends out all of its CSs, i.e., Station  $T$  does not sense channel busy in CP. If a station is also in the collision domain of  $R$  (in this example,  $O_1, O_2$  and  $R$ ), it is already considered in  $\alpha_1$  and shall not be included here. Thus, there are  $(n_t - n_o - 1)$  stations<sup>1</sup> applied to  $\alpha_2$ , such as  $T_2$  and  $T_3$  as shown in Fig. 5.

For a given  $k_t$  of Station  $T$ ,  $T$  will not hear any ongoing transmission in CP if none of its neighbors has a contention number larger than  $k_t$ . The probability of a station having a contention number smaller or equal to  $k_t$  is  $\frac{k_t+1}{2^K}$ . Clearly,  $\alpha_2$  can be obtained as

$$\alpha_2 = f_2(k_t) = \left( \frac{k_t + 1}{2^K} \right)^{n_t - n_o - 1}. \quad (3)$$

In multihop networks, a station could win channel competition even though it does not have the largest contention

<sup>1</sup>Note that,  $n_t - n_o \geq 1$ .

number. Such events will be analyzed in Section IV-B.

At last,  $\alpha_3$  is the probability that  $T$  receives the HCM correctly from  $R$ , i.e., there is no other neighbor of  $T$  marks itself as the receiver when  $R$  is sending HCM to  $T$  during HEP. In our analysis,  $n_t$  is used as the average number of stations in the interference range, other than the receiver. As shown in Sections IV-B and V, such approximation provides reasonably accurate numerical results.

If any other station in the interference range of Station  $T$  transmits HCM, Station  $T$  has to give up. For example,  $T_2$  has a probability of  $\frac{1}{n_c}$  to be selected as the receiver by  $T_3$ . With  $n_c$  stations in the communication range, there is a total probability of  $\frac{n_c-1}{n_c}$  for  $T_2$  to be an intended receiver. If  $T_2$ 's transmitter generates a bigger number than  $k_t$ ,  $T_2$  will mark itself as the receiver and sends HCM, and thus  $T$  could not receive its HCM correctly. Given  $\alpha_1$ , Stations  $O_1$ ,  $O_2$  and  $R$  will be excluded to avoid double calculation. Therefore, the probability of  $\alpha_3$  can be derived as

$$\alpha_3 = f_3(k_t) = \left(1 - \frac{n_c - 1}{n_c} \sum_{y=k_t+1}^{2^K-1} \frac{1}{2^K} \frac{y}{2^K}\right)^{n_t - n_o - 1}. \quad (4)$$

Finally, the above analysis is based on a specific  $k_t$  generated by the transmitter. The stationary transmission probability (i.e., the probability that a station can transmit data in one frame) for the primary data transmission can be derived as

$$\tau_{pd} = \frac{1}{2^K} \sum_{k_t=0}^{2^K-1} f_1(k_t) f_2(k_t) f_3(k_t). \quad (5)$$

The proposed analytical model only considers the overlapping case between the transmitter and the receiver, which works well for networks with low and moderate nodal densities. In the dense networks, there are much more common neighbors between two adjacent stations. Our model may not be sufficient to remove all overlapping nodes in the calculation.

### B. Chain Reaction from the Remote Stations

In Section IV-A, it is shown that when a station has the largest contention number in its collision domain, it will always sense the channel to be idle and therefore moves to the next interval. However, under certain scenarios, it is possible that the station still wins the channel contention even though some neighbor has a bigger contention number.

An example of a chain network is given in Fig. 6, where Station  $T$  is trying to send data to Station  $R$ . First, suppose there are only four stations in the network ( $T+1$ ,  $T$ ,  $R$  and  $R+1$ ) and assume  $k_t = 0010$ ,  $k_{t+1} = 0011$  and both  $R$  and  $R+1$  generate smaller contention numbers than  $T$  does. As a result,  $T$  has to give up its transmission attempt in the 4<sup>th</sup> slot when it hears the CS sent by  $T+1$ . However, with Stations  $T+2$  and  $T+3$  joining in the network as shown, the situation becomes less predictable. Assume  $T+2$  generates 0100 as its random number. Then  $T+1$  will give up channel access after the first contention slot and hence give  $T$  the opportunity to transmit all its CSs.

In general, when  $k_t$  is smaller (than  $k_{t+1}$ , for example), Station  $T$  still has chance to win the channel contention if  $T+1$

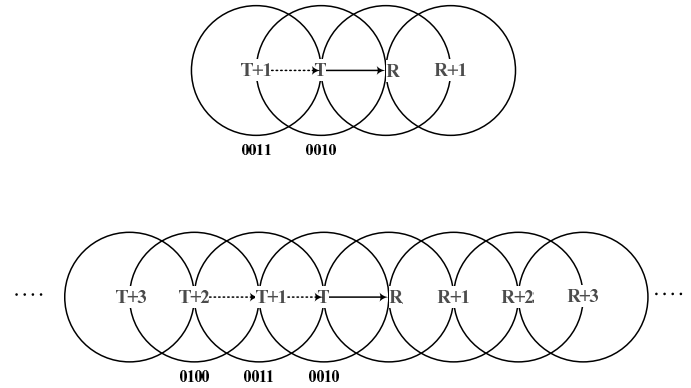

Fig. 6. The influence to data transmission from remote stations.

has a neighbor (e.g.,  $T+2$ ) with a bigger contention number. Whether  $T$  can win the channel depends on the highest bit position at which the random numbers (i.e.,  $k_{t+2}$ ,  $k_{t+1}$  and  $k_t$ ) have different values. Denote such bit position to be  $i$ , i.e., these random numbers have all 0's or all 1's at any bit higher than the  $i$ <sup>th</sup> bit. Given  $k_{t+2} > k_{t+1} > k_t$ , the  $i$ <sup>th</sup> bit of these random numbers may have one of the following two combinations:

- 1) The  $i$ <sup>th</sup> bit of  $k_{t+2}$ ,  $k_{t+1}$  and  $k_t$  are "1", "1" and "0" respectively. Then in contention slot  $i$ ,  $T$  hears a CS sent by  $T+1$  before  $T+1$  knows  $T+2$  is competing the channel. Thus  $T$  will give up channel access;
- 2) The  $i$ <sup>th</sup> bit of  $k_{t+2}$ ,  $k_{t+1}$  and  $k_t$  are "1", "0" and "0" respectively (as illustrated in Fig. 6). Then in contention slot  $i$ ,  $T+1$  hears a CS from  $T+2$ , and hence gives up before  $T$  receives anything from  $T+1$ . As a result,  $T+1$  goes to sleep while  $T$  stays in competition. In this case, the actual number that  $T+1$  has sent out is smaller than  $k_t$ .

Clearly, these two events have equal chances to appear, and thus  $T$  has a probability of 0.5 to win the channel competition with  $k_{t+2} > k_{t+1} > k_t$ .

Given  $k_t$ , the probability that  $T$  does not hear the contention signal (CS) from  $T+1$  is

$$(n_c - 1) \sum_{k_{t+1}=k_t+1}^{2^K-1} \frac{1}{2} \frac{1}{2^K} \frac{2^K - k_{t+1} - 1}{2^K}. \quad (6)$$

Therefore  $\alpha_2$  should be rewritten as

$$\begin{aligned} \alpha_{2a} &= \frac{k_t + 1}{2^K}, \\ \alpha_{2b} &= (n_c - 1) \sum_{k_{t+1}=k_t+1}^{2^K-1} \frac{1}{2} \frac{1}{2^K} \frac{2^K - k_{t+1} - 1}{2^K}, \\ \alpha_2 &= f_2(k_t) = (\alpha_{2a} + \alpha_{2b})^{n_t - n_o - 1}. \end{aligned} \quad (7)$$

Theoretically, every station in a connected multihop network will influence  $\alpha_2$  remotely, through the effect described above. For example, in Fig. 6, let Station  $T+3$  also participate the channel contention. If  $k_{t+3}$  is 1000, then  $T+2$  has to give up its transmission attempt after the first contention slot. The existence of  $T+2$  increases the probability that  $T$  always senses the channel to be idle in the contention interval ( $\alpha_2$ ); on the contrary,  $T+3$  reduces  $\alpha_2$ . Such "chain

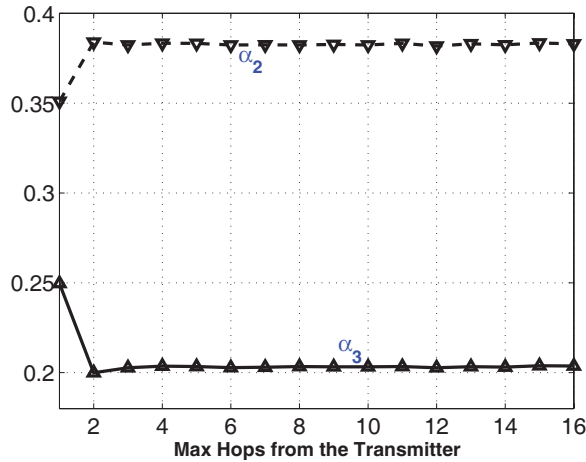

Fig. 7. Remote stations impact the transmission probability.

reactions” alternatively influence  $\alpha_2$  through a sequence of stations multiple hops away.

On the other hand, the remote stations reversely influence the value of  $\alpha_3$ . For example, if  $T + 2$  in Fig. 6 selects  $T + 1$  as its receiver, then  $T$  has to give up transmission due to the HCM collision even though it successfully sends out all its CSs. This effect, which has been considered in the calculation of  $\alpha_3$ , partially cancels out the throughput improvement due to the increased  $\alpha_2$  and causes the reaction chain less regular.

Although any remote station in the network will impact the stationary throughput remotely, the degree of the influence drops sharply when the hop distance increases. Fig. 7 shows the change to  $\alpha_2$  and  $\alpha_3$  in the transmission from T to R, when the chain grows and the number of maximum hops from the transmitter increases. It can be observed that when the chain increased from one hop (i.e., Station  $T + 1$  has no other neighbor except Station  $T$ ) to two hops (i.e., Station  $T + 2$  is added in the chain),  $\alpha_2$  increases because there is a probability that Station  $T + 2$  will prevent  $T + 1$  from sending CS. In the mean time,  $\alpha_3$  decreases because Station  $T + 1$  is more likely to send HCM and causes collision at Station  $T$ . When the chain further increases, the influence from the remote stations 2-hop away is negligible. The chain reaction from the receiver has similar effects. Therefore, our model only considers the impact of a remote station up to 2-hop. The approximation significantly reduces the complexity in our model without losing the accuracy, and thus makes the multihop networks modeling much more manageable.

### C. The Second Chance Transmission

According to the rule of DFA, the stations that failed to win the channel during CP1 and HEP1 can have second chances, as long as they hear neither HCM nor data transmission. In our model,  $\tau_{pd}$  is the probability of a station sending data successfully after HEP1, and it is also the approximated probability of the station correctly receiving data from any of its neighbors.  $(1 - 2\tau_{pd})$  is thus the probability of a station giving up after the HEP1. The stationary probability for the second chance transmission with DFA can be derived as:

$$\tau_{sc} = \tau_{pd}'(1 - 2\tau_{pd})^{n_t + n_r - n_o}. \quad (8)$$

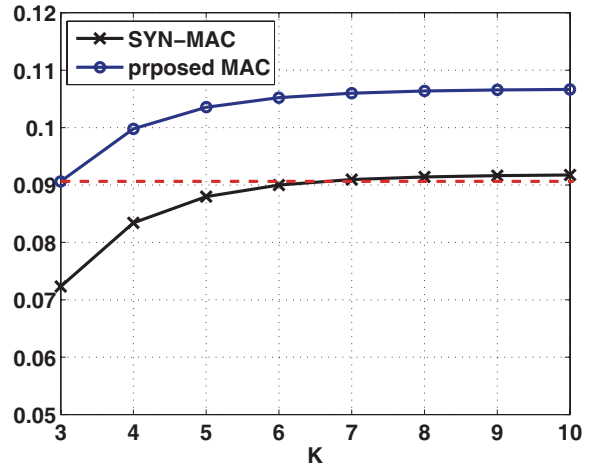

Fig. 8. Transmission probability with different K values.

where  $\tau_{pd}'$  is obtained by Eqs. 2- 7, with

$$\begin{aligned} n_{t'} &= n_t(1 - 2\tau_{pd}), \\ n_{r'} &= n_r(1 - 2\tau_{pd}), \\ n_{o'} &= n_o(1 - 2\tau_{pd}), \\ n_{c'} &= n_c(1 - 2\tau_{pd}). \end{aligned}$$

And the transmission probability of DFA is obtained as:

$$\tau = \tau_{pd} + \tau_{sc}. \quad (9)$$

The actual data throughput of the secondary transmission is smaller than the primary transmission, due to the added overhead of SP, CP2 and HEP2. Therefore,  $\tau_{pd}$  and  $\tau_{sc}$  need to be calculated separately to get the stationary throughput  $\Gamma$ :

$$\Gamma = \tau_{pd} \times \frac{l_{d1}}{l_{frame}} + \tau_{sc} \times \frac{l_{d2}}{l_{frame}}, \quad (10)$$

where  $l_{d1}$  is the length of data payload in frame type 1, and  $l_{d2}$  is the length of data payload in frame type 2. And  $l_{frame}$  as the frame length.

By adopting the second chance transmission, our proposed protocol can achieve better transmission probability with less contention slots than the SYN-MAC protocol in multihop networks. Fig. 8 compares the transmission probabilities of DFA and SYN-MAC with different values of  $K$  in hexagon network. As depicted in the figure, DFA with 3 contention slots achieves approximately the same transmission probability as SYN-MAC with 10 contention slots, implying the DFA effectively reduces the overhead for data transmission. If both protocols use the same  $K$ , a transmission gain of 15%-25% is shown in the figure. Such improvement happens in multihop networks. For single hop, all stations have the symmetric and complete information about the channel status and DFA yields the same successful transmissions as SYN-MAC, which is greater than 90% [1].

## V. SIMULATION AND NUMERICAL RESULTS

Extensive simulations are carried out to validate the analytic model and the performance of DFA. All of our simulations are based on the interference range of 1.78 times of the transmitter-receiver distance [18]. It is assumed that a source

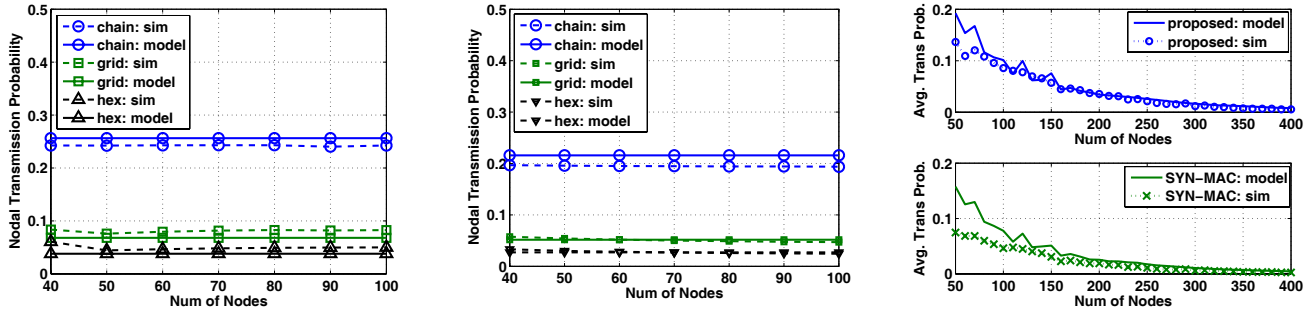

(a) Stationary transmission probabilities of DFA with fixed nodal density. (b) Stationary transmission probabilities of SYN-MAC with fixed nodal density. (c) Stationary transmission probabilities with increased nodal densities in random networks.

Fig. 9. Model validation.

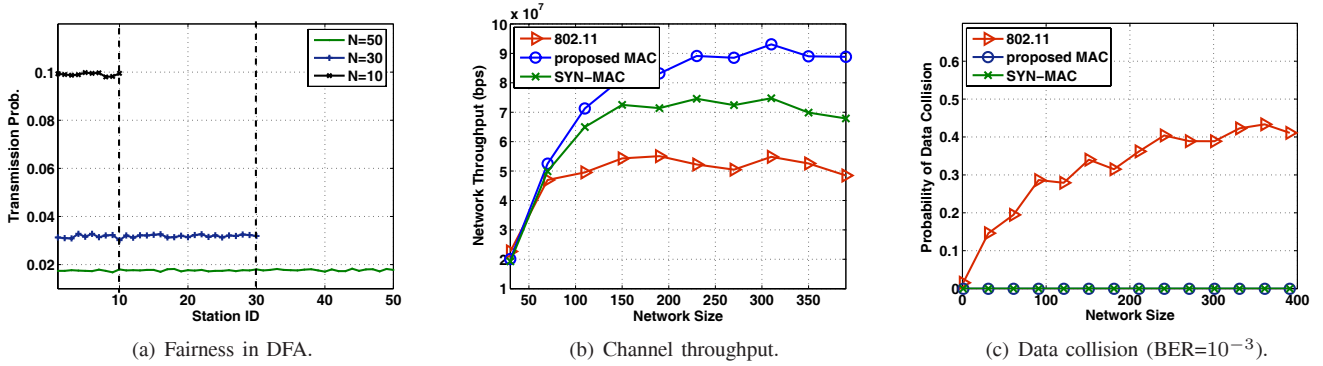

Fig. 10. Protocol comparison. (BER=10<sup>-3</sup>).

station randomly selects one neighbor as its destination for each frame. In Fig. 9, the numerical analysis of SYN-MAC and DFA is validated by the simulation results with  $K$  set to 3. As explained in Section IV,  $\tau_{pd}$  is the transmission probability for the SYN-MAC protocol. First of all, the proposed model is tested on uniform networks with fixed nodal densities, as depicted in Figs. 9(a) and 9(b). Three different network topologies (i.e., chain, grid and hexagon topologies) are used. The network size ranges from 40 to 100. The nodal deployment of the grid and hexagon topologies starts from  $4 \times 10$  to  $10 \times 10$ . For each deployment, a station in the center of the network is selected to calculate the transmission probability  $\tau$ . It can be observed that the simulation matches our numerical analysis regardless of the number of hops between the transmitter and the receiver, which confirms our analysis with two-hop approximation. The stationary transmission probability of the DFA protocol is higher than that of the SYN-MAC protocol, with the help of the second chance transmission. It is also clear that  $\tau$  decreases when the network density grows, due to the increased channel competition and collision.

Fig. 9(c) further validates the model with various random networks. Assume the average number of neighbors of a station  $\bar{n}$  and average overlapping stations  $\bar{n}_o$  are the only given information about the network. With the network area of  $10 \times 10$  and the nodal communication range of 1, the number of stations in the networks ranges from 10 to 400. When the network size grows in a fixed area, naturally the number of neighbors for every station increases. The numerical analysis is observed to have better match with the simulation when  $\bar{n}$  is big. It is because the bigger  $\bar{n}$  results in more evenly

distributed nodal densities; therefore it is more accurate when using average nodal densities for approximation.

Fig. 10 highlights the attractive features of DFA. Fig. 10(a) shows the fairness (i.e., the probability that a station can transmit data in one frame) of DFA in single hop networks of 10, 30 and 50 stations, respectively. Since all stations can acquire complete and symmetric channel information in single hop networks, they should have the same transmission probabilities, as verified in the figure. The slight oscillations in transmission probability for each station are due to the random nature of the contention number. The overall transmission probabilities of the networks are over 95%, showing that DFA can achieve very high channel utilization.

Fig. 10(b) compares the network throughput of the IEEE 802.11 DCF, SYN-MAC and DFA, with the same network deployments as in Fig. 9(c) and 11 Mbps bandwidth. To consider the impact of error-prone physical medium, a bit-error-rate (BER) of  $10^{-3}$  is used in simulation. For DFA or SYN-MAC, every packet contains a 48-bit PLCP header and 32-bit CRC. There is a  $2 \mu s$  guard band placed between adjacent time slots, as described in Sec. III-C. A CS frame has the receiver's MAC address, and an HCM frame has  $K$ -bit contention mask. A payload size of 8184 bits is included in the data packet of SYN-MAC and DFA (Type 1 frame). The payload of Type 2 frame of DFA is shorter (6262 bits), in order to accommodate the second chance contention. The number of contention slots  $K$  for both protocols is 6. There are  $5 \mu s$  turnaround time between the transmitting and the receiving modes and  $3 \mu s$  propagation time included in each time slot. For DCF, each packet contains a physical header of

128 bits (including preamble bits for packet synchronization) and CRC. The contention window sizes are from 32 to 1028. The slot time is 50  $\mu$ s, and the data payload is 8184 bits. The MAC header of 240 bits in data packet is applied for all protocols.

Fig. 10(b) shows that DFA achieves the highest network throughput, regardless of the network size and density. Fig. 10(c) demonstrates the data packet collisions caused by multiple transmissions. The increased network size introduces more intensive channel contention, and results in higher growth of data collision in DCF. However, the DFA inherits the advantages of SYN-MAC and provides collision free data transmission at all time. Note if we increase the length of data period to allow multiple data packets to be transmitted in the same frame as explained previously, the throughput gain of DFA over DCF will be greater.

## VI. CONCLUDING REMARKS

In this paper, the Distributed and Fair Access (DFA) protocol has been proposed for multihop wireless networks. DFA eliminates such problems existed in the original binary countdown algorithm, as lack of fairness, data collision and inefficiency of channel usage, by introducing hidden-station elimination and the second chance transmission. Further, the numerical analysis on modeling the behavior of DFA in multihop networks has been introduced in the paper. With the proposed model, the data transmission influenced by the remote stations from the transmitter has been carefully monitored and analyzed. Our analysis predicts the channel throughput and transmission probability in multihop scenarios. The proposed model has been verified by simulations, which demonstrated the superior performance of DFA comparing with the existing MAC protocols including the IEEE 802.11 DCF and SYN-MAC. Equipped with many attractive features such as high efficiency, fairness, simplicity and robustness, DFA can be served as a promising alternative MAC protocol in the distributed wireless networks.

## REFERENCES

- [1] H. Wu, A. Utgikar, and N.-F. Tzeng, "SYN-MAC: distributed medium access control protocol for synchronized wireless networks," *ACM Mobile Networks & Applications*, vol. 11, pp. 627–637, Feb. 2005.
- [2] S. Xu and T. Saadawi, "Does the IEEE 802.11 MAC protocol work well in multihop wireless ad-hoc networks?" *IEEE Commun. Mag.*, vol. 39, no. 6, pp. 130–137, June 2001.
- [3] M. Garetto, J. Shi, and E. W. Knightly, "Modeling media access in embedded two-flow topologies of multi-hop wireless networks," in *Proc. 11th Annual International Conference on Mobile Computing and Networking (MobiCom '05)*, Aug. 2005, pp. 200–214.
- [4] G. Brar, D. M. Blough, and P. Santi, "Computationally efficient scheduling with the physical interference model for throughput improvement in wireless mesh networks," in *Proc. 12th Annual International Conference on Mobile Computing and Networking (MobiCom'06)*, Sept. 2006, pp. 2–13.
- [5] T. Ue, S. Sampei, N. Morinaga, and K. Hamaguchi, "Symbol rate and modulation level-controlled adaptive modulation/TDMA/TDD system for high-bit-rate wireless data transmission," *IEEE Trans. Veh. Technol.*, vol. 47, pp. 1134–1147, Nov. 1998.
- [6] Z. Cai and M. Lu, "SNDP: a new medium access control for multi-channel ad hoc networks," in *Proc. Vehicular Technology Conference (VTC'00)*, May 2000, pp. 966–971.
- [7] C. M. Chao, J. P. Sheu, and I. C. Chou, "A load awareness medium access control protocol for wireless ad hoc network," in *Proc. IEEE International Conference on Communications (ICC'03)*, vol. 1, May 2003, pp. 438–442.

- [8] G. Bianchi, "Performance analysis of the IEEE 802.11 Distributed Coordination Function," *IEEE J. Select. Areas Commun.*, vol. 18, no. 3, pp. 535–547, Mar. 2000.
- [9] Y. Xiao, "Performance analysis of priority scheme for IEEE 802.11 and IEEE 802.11e wireless LANs," *IEEE Trans. Wireless Commun.*, vol. 4, pp. 1506–1515, July 2005.
- [10] H. Wu, Y. Peng, K. Long, S. Cheng, and J. Ma, "Performance of reliable transport protocol over IEEE 802.11 Wireless LANs: analysis and enhancement," in *Proc. 21st Annual Joint Conference of the IEEE Computer and Communications Societies (INFOCOM'02)*, vol. 2, June 2002, pp. 599–607.
- [11] P. Gupta and P. Kumar, "The capacity of wireless networks," *IEEE Trans. Inform. Theory*, vol. 46, no. 2, pp. 388–404, Mar. 2000.
- [12] M. Grossglauser and D. N. C. Tse, "Mobility increases the capacity of ad-hoc wireless networks," *IEEE/ACM Trans. Networking*, vol. 10, no. 4, pp. 477–486, Aug. 2002.
- [13] F. Alizadeh-Shabdiz and S. Subramaniam, "Analytical models for single-hop and multi-hop ad hoc networks," *ACM Mobile Networks & Applications*, vol. 82-B, no. 1, pp. 75–90, Jan. 2006.
- [14] K. Xu, M. Gerla, and S. Bae, "How effective is the IEEE 802.11 RTS/CTS handshake in ad hoc networks," in *Proc. IEEE Global Telecommunications Conference (GLOBECOM '02)*, vol. 1, Nov. 2002, pp. 72–76.
- [15] K. Wang, F. Yang, Q. Zhang, and Y. Xu, "Modeling path capacity in multi-hop IEEE 802.11 networks for QoS services," *IEEE Trans. Wireless Commun.*, vol. 6, no. 2, pp. 738–749, Feb. 2007.
- [16] S. PalChaudhuri, A. K. Saha, and D. B. Johnson, "Adaptive clock synchronization in sensor networks," in *Proc. Third International Symposium on Information Processing in Sensor Networks (IPSN'04)*, Apr. 2004, pp. 340–348.
- [17] S. Bregni, L. Lacavalla, B. Propersi, and F. Residori, "Synchronization of single-frequency simulcast networks using network time protocol," in *Proc. IEEE International Conference on Communications (ICC'07)*, June 2007, pp. 6129–6134.
- [18] K. Xu, M. Gerla, and S. Bae, "Effectiveness of RTS/CTS handshake in IEEE 802.11 based ad hoc networks," *J. Ad Hoc Networks*, vol. 1, pp. 107–123, July 2003.



**Lei Pan** received her M.S. degrees in Computer Science and MBA in Information System from the University of Louisiana at Lafayette in 2005 and 2002, respectively. She is now working toward the Ph.D. degree in Computer Science in the Center for Advanced Computer Studies (CACS), the University of Louisiana at Lafayette. Her current research interests include wireless ad hoc networks, wireless mesh and sensor networks, MAC protocol design and analysis, QoS and wireless network capacity.

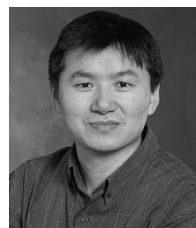

**Dr. Xiaojun Cao** received his B.S. from Tsinghua University and M.S. from Chinese Academy of Sciences. In 2004, he received his Ph.D. degree in Computer Science and Engineering from the State University of New York at Buffalo. He is currently an assistant professor with the Department of Computer Sciences at Georgia State University. Dr. Cao's research interests relate to modelling, analysis, and protocols/algorithms design of communication networks including optical and wireless networking. Dr. Cao is a recipient of the NSF CAREER Award.

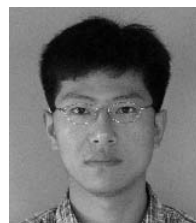

**Hongyi Wu** (M'02) received his Ph.D. degree in Computer Science and M.S. degree in Electrical Engineering from State University of New York (SUNY) at Buffalo in 2002 and 2000, respectively. He received his B.S. degree in Scientific Instruments from Zhejiang University in 1996. He is currently an Associate Professor at the Center for Advanced Computer Studies (CACS), University of Louisiana (UL) at Lafayette. His research interests include wireless mobile ad hoc networks, wireless sensor networks, next generation cellular systems, and integrated heterogeneous wireless systems. He has served as chair and technical committee member of several IEEE conferences, and a guest editor of ACM MONET special issue on Integration of Heterogeneous Wireless Technologies. He has published more than two dozens of technical papers in leading journals and conference proceedings. He received NSF CAREER Award in 2004.